

Better.  
Brighter.  
Brand New.

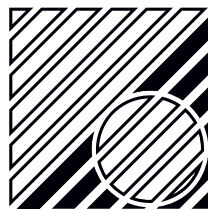

**CONCEALITE**

LIFE SAFETY PRODUCTS

A Division of Gow Industries, Inc.

## HYDRO-FORM I&II

### Architectural Features

- Unit is available up to a 200 Watt output.
- Unique 100 Watt high output quartz halogen lamps vs. competitors 7.2 Watt lamps.
- Power unit offers a decorative architectural solution of an aluminum exterior housing and unique sealed fiberglass laminate interior containment system for complete wet location protection against dust, dirt, corrosive atmospheres and water spray (hose down).
- Custom colors, finishes, and textures available at the factory to match your exterior (custom color shown here).
- 12 Volt model.
- Fully adjustable gasketed wet location aluminum heads with locking swivel.
- Maintenance-free lead calcium battery.
- Alternate battery types available please contact factory.
- 90 minutes of illumination standard. Alternate run times available please contact factory.
- Universal input 120/277 VAC.
- Operating temperature 32 degrees F to 104 degrees F (0 degrees C to 40 degrees C). Sub zero heater available.
- Fully automatic, temperature compensating, variable rate charger.
- Low voltage disconnect.
- Automatic brownout protection.
- AC lockout to reduce installation time.
- Self diagnostics is an available option.
- Sealed momentary test switch and AC ready light.
- Single and dual matching remote head assemblies with mounting plate available in 12 and 120 Volts.
- NFPA 101, NEC, OSHA, State and Local codes.
- UL 924 wet location listed. 

We can  
custom finish  
to blend in.

### HYDRO-FORM EXTERIOR WET LOCATION (SELF-CONTAINED)



**HYDRO-FORM**  
Semi Recessed with Trim Mounting Kit

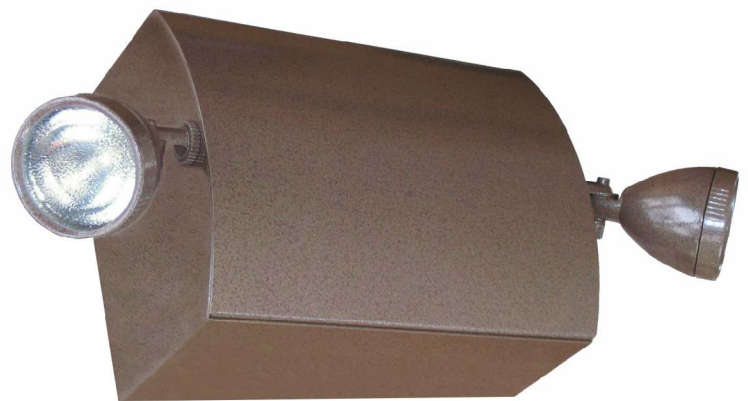

**HYDRO-FORM**  
Surface Mount



# HYDRO-FORM I & II

## Installation

Mount the unit utilizing the holes indicated and the mounting hardware supplied. Designed for installation on most exterior surfaces including concrete, block, and brick. See instruction sheets for details.

## Illumination

The fully adjustable heads are UL listed for wet location applications. Specially designed high output halogen lamps are available in 20, 35, 50, 75, and 100 Watts. Concealite provides free point by point lighting layout service for code compliance. Contact your local Concealite representative for details.

## Product Specifications

The emergency lighting unit shall be Concealite Series HF and will conform to UL Standard 924 and be installed in accordance to Article 700 of the National Electrical Code. The unit shall consist of an aluminum exterior housing and unique sealed fiberglass NEMA 4X type laminate interior containment system for complete wet location protection against dust, dirt, corrosive atmospheres and water spray (hose down). The unit shall be supplied with one or more UL Standard 924 listed heads. The lighting head shall be fully adjustable gasketed wet location rated with locking swivel. The electronics shall include a fully automatic, temperature compensating variable rate charger. The unit shall include LVD and brownout circuits. The charger shall be rated at 120/277 VAC, 60 HZ (347 VAC optional) The unit shall have an integral test switch and pilot light. Upon the loss of utility power the unit's lamp(s) will energize. When utility power is restored, the lamps will extinguish. The maximum power draw will be no more than 15 Watts. When utility power is restored the charger will bring the battery back to full charge within UL Standard 924 time requirements.

## Limited Warranty

All Concealite equipment is guaranteed against defects in materials and workmanship by the manufacturer for a period of three years from date of shipment under normal operations and proper use. Correction of all defects shall be by replacement or repair (at our discretion) and shall constitute fulfillment of all manufacturer's obligations.



### Surface Mount

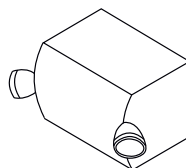

#### HYDRO-FORM I

100 WATT TOTAL CAPACITY

##### Dimensions

9"H x 12 1/4"W x 9 1/8" Depth  
(22.86 cm H x 31.12 cm W x 23.17 cm Depth)

#### HYDRO-FORM II

200 WATT TOTAL CAPACITY

##### Dimensions

13"H x 16 3/8"W x 9 1/8" Depth  
(33.02 cm H x 41.59 cm W x 23.17 cm Depth)

### Semi-Recessed Option

1" Wide Semi-recessed Trim Mounting Kit Ordering Option **SR**

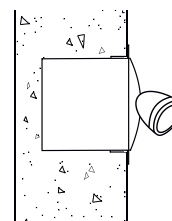
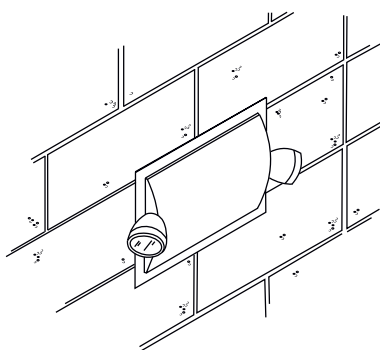
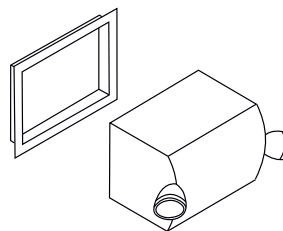

**Note:** Semi-recessed option allows universal field adjustable depth up to 8" deep.

## Ordering Information

Series	HF	II	100	90	OPTIONS
<b>HYDRO-FORM Size</b>					
I					
II					
<b>High Output Lamps</b>					
20					
35					
50					
75					
100					
<b>Hours of Operation</b>					
90					
XX					
<b>Options</b>					

<b>SD</b>	Self-Diagnostic Charger & Monitoring System
<b>TD-120</b>	15 Min Time Delay (120v)
<b>TD-277</b>	15 Min Time Delay (277v)
<b>220V</b>	220v - 50Hz input transformer
<b>H-120</b>	Battery Heater (120v)
<b>H-277</b>	Battery Heater (277v)
<b>NC</b>	NiCad Battery Pack (Contact Factory)
<b>PL</b>	Pure Lead Battery Pack (Contact Factory)
<b>CL</b>	36" 3 Conductor Weatherproof Line Cord
<b>SR</b>	Semi-Recessed Trim Mounting Kit
<b>RL</b>	Remote Leads (To Serve Remote Lighting Heads)
<b>CF</b>	Custom Finish

**Note:** To specify matching wet location remote H Series heads, AC inverters and DC central battery systems refer to the Concealite H Series catalog sheet or contact Concealite for more info.



A Division of Gow Industries, Inc.

202 Elk Street, P.O. Box 160  
Elkton, SD 57026  
Phone: (605)542-4444  
Fax: (605)542-3333  
www.concealite.com